

BIOINFORMATICS AND EVOLUTION OF CELL WALLS IN FUNGI

Bioinformatics and protein structure:

We use bioinformatic tools to compare properties of protein sequences. The amino acid sequences tell what types of domains are present, and predict how they fold. The homology modeling shown on the **AGGLUTININS** page is one example of this approach. Another is our current project to model the Threonine-rich glycosylated repeats in **ALS PROTEINS**.

Comparative studies are exemplified in an illustration of the sequences of fungal agglutinins and adhesins. The figure below was generated with the program DRAWHCA available through the EXPASY website. The figure illustrates repeat sequences (as boxed regions with recurring patterns); Cysteine residues as triangles placed beneath the sequences; N-glycosylation sites as hexagons above the sequences; and the frequency of threonine residues as dotted and solid lines beneath the sequences.

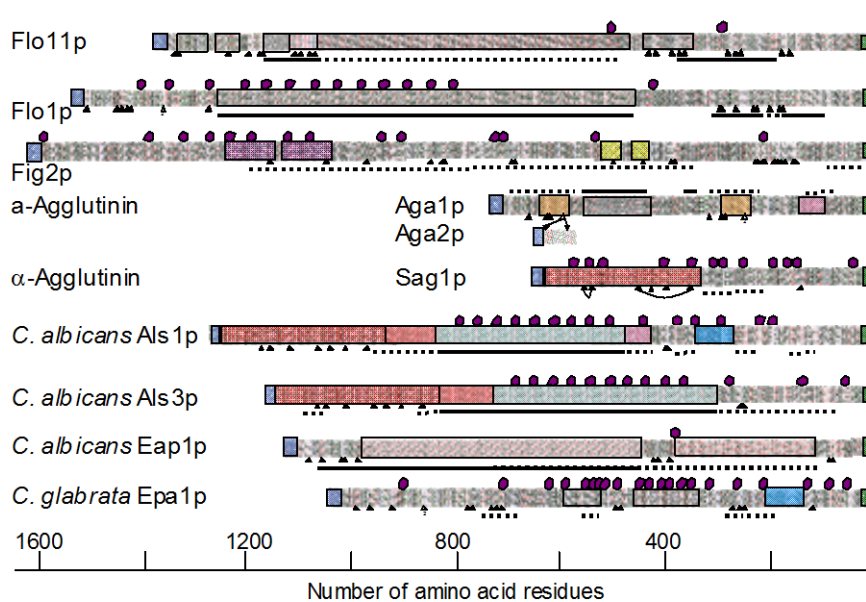

Evolution of Fungal Cell Walls

In collaboration with Dr. Wei-Gang Qiu and Dr. Susan Epstein of Hunter College, Juan Coronado has devised a new tool for comparison of serine- and threonine-rich sequences like those in cell wall proteins. We have used Juan's method to study the evolution of cell wall proteins, and to study how fungal cell walls came to be developed, considering that the animals are the eukaryote kingdom most-closely related to fungi.

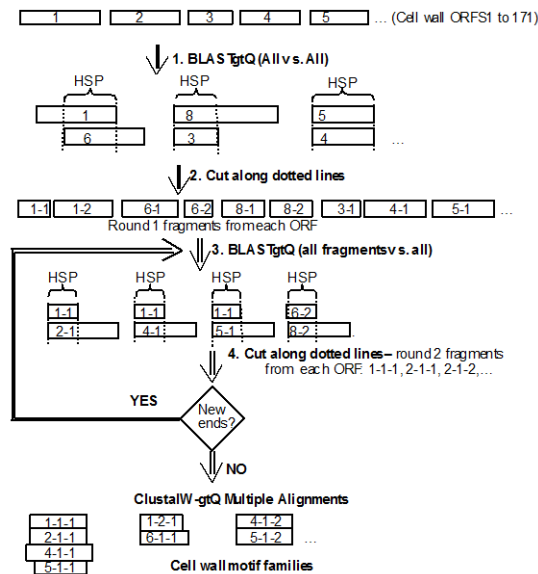

Procedure for identifying repeated motifs in cell wall proteins from the MATCH paper cited below

[Coronado, J.E., O. Attie, S.L. Epstein, W.-G Qiu, and P.N. Lipke. 2006. Composition-modified matrices improve identification of homologs of *S. cerevisiae* low-complexity glycoproteins. Euk. Cell 5: 628-637.](#)

[Romov, P.A., F. Li, P.N. Lipke, S.L. Epstein, and W.G. Qiu, W.-G. 2006. Comparative genomics reveals long, evolutionarily-conserved, low-complexity islands in yeast proteins. J. Mol. Evolution 63: 415-425.](#)

Coronado, J.E., W.-G. Qiu, S.L. Epstein, and P.N. Lipke. 2007. Discovery of repeated sequence motifs in yeast cell wall proteins. MATCH: DIMACS 2006 in press